

Summer 2024 | Vol. 34 No. 2

# The Bulletin

National Tractor Parts Dealer Association

Scholarship Recipients

Meet Our Members

Family Money  
with Craig Shaver





**2024 NTPDA OFFICERS**

President  
Trey Russell ~ 800-248-8883  
Russells Tractor Parts • Scottsboro, AL

Vice President  
Dan Waters ~ 509-346-2028  
Waters Tractor, LLC • Othello, WA

Treasurer  
Glen Leaders ~ 800-950-9917  
Leaders Tractor & Combine Salvage • Dunlap, IA

Secretary  
Terri Stevens ~ 800-383-3678  
The Tractor Barn, Inc. • Brookline, MO

**BOARD OF DIRECTORS**

Harry Bottomstone ~ 800-451-5240  
Wengers of Myerstown • Myerstown, PA

Richard Cook ~ 660-885-9201  
Cook Tractor Parts • Clinton, MO

Cody Levan ~ 800-626-6046  
Schaefer Enterprises • Wolf Lake, IL

Dustin Raschein ~ 541-928-1646  
Farmland Tractor Supply • Tangent, OR

Tom Roelofsen ~ 800-255-0337  
Abilene Machine, LLC • Abilene, KS

Dave Sudbrink ~ 877-530-1010  
All State Ag Parts • Downing, WI

**ASSOCIATE DIRECTORS**

Brandi Erickson ~ 800-234-3280  
Steiner Tractor Parts • Lennon, MI

Mark Ziemann ~ 800-328-1752  
K&M Manufacturing • Renville, MN



**INSIDE**

	Page
PRESIDENT'S PEN .....	3
STAFF NOTES .....	5
AGING AND FINANCE..... <i>Craig Shaver</i>	7
DID YOU KNOW? .....	9
MEMBER NEWS.....	11
SCHOLARSHIP RECIPIENTS.....	12-14
LET'S EAT .....	15
ADVERTISING/MARKETING TIP .....	23
<i>Michael Libbie</i>	
SUMMER MIXER.....	24
GREASY GIRL.....	25
<i>Terri Stevens</i>	
THANK YOU ADVERTISERS.....	28



***BULLETIN***

MICHAEL LIBBIE, Editor

Articles, letters, advertisements and comments are encouraged. Send to:

P.O. Box 1181  
Gainesville, TX 76241

**NTPDA**

KIM CARROLL  
*Operations Manager  
Meeting Planner/Event Coordinator*

MICHAEL LIBBIE  
*Business Development - Recruitment/Retention*

940-668-0900 • Toll Free 877-668-0900  
Fax 940-668-1627

email: [ntpda@ntpda.com](mailto:ntpda@ntpda.com)

The National Tractor Parts Dealer Association makes every reasonable effort to ensure accuracy of information contained in the *Bulletin* and to give credit to original authors where applicable. NTPDA and/or its agents are not responsible for errors or omissions.

From the President's Pen ...



## Schooooool's Out For Summer

What a crazy time of year!! Kids are starting summer vacation, graduations, and family vacations. Farmers are planting crops, cutting hay and preparing to harvest wheat. If your business looks like ours, your phones are going crazy and customers are filling up the parking lot. This is why we put in the investment and effort. Your Association handed out 25 scholarships to this year's graduating class. That is awesome! What an amazing investment for the future. Thank you to the members of the scholarship committee!! (Marian Levan, Eric Shaul, Jake Walmer, Renae Jensen, Erika Sudbrink).



President Trey

Phones are ringing and I have to go. Hope everyone has a great summer.

Keep Grindin'!

Trey

## YOUR INVITATION TO THE Summer Mixer

*July is going to heat up and that's the month we hold our Summer Mixer. While this has always been the Summer Board Meeting, we've started to take it to a whole new level of FUN!*

*Yes, the Board does meet but we've also opened up the event to every NTPDA Member to join us for a couple of days of socializing and getting to know each other better. We recently headed to Alabama and had a great time in Scottsboro with Russell's Tractor who put on an amazing event that saw attendees make a site visit, eat some pizza and a shrimp boil that was over the top. Not to be outdone, this past year Wenger's of Myerstown hosted the Summer Mixer in Pennsylvania and what a great time we had learning about the history of the area, dining in some really great old family restaurants and checking out their family business.*

*So, here is your invitation to join us for our next Summer Mixer this coming July. We would love to have you with us!*

**TVH<sup>®</sup>**

**THIS IS NOT  
JUST A  
TRACTOR.**

**IT'S ALL OF THE  
PARTS THAT KEEP  
IT OPERATING ALL  
SEASON LONG.**



**[WWW.TVH.COM](http://WWW.TVH.COM)**

# CallNote

Call Management for the Parts Department

Maximize Efficiency  
Minimize Mistakes

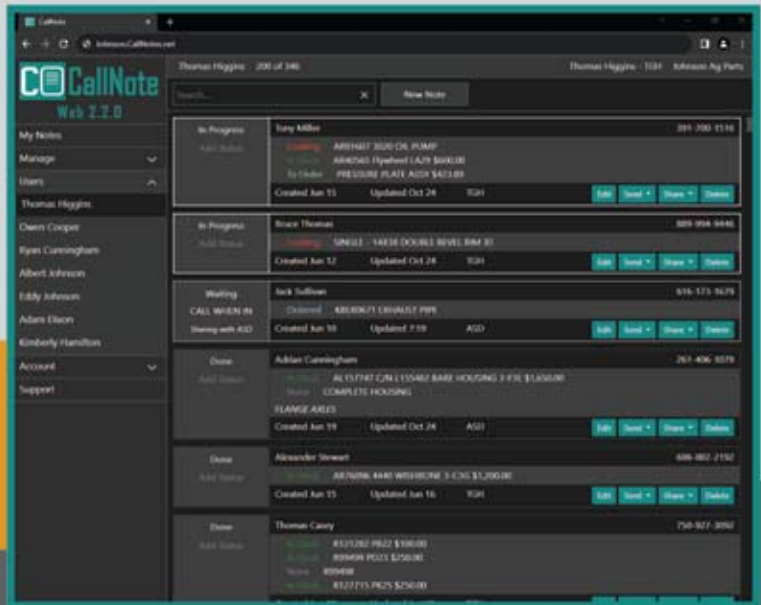

- Keep up-to-date status on notes and individual parts
- Intuitive wildcard search shows other users with matches
- Easily update any note in one click
- Live sync keeps everyone up to date all the time
- Integrates with other inventory management software
- Fully compatible with any device

Get your demo today

937-670-9504

sales@callnotes.net

[www.callnotes.net](http://www.callnotes.net)



## RECENTLY SHIPPED

FARM EQUIPMENT  
CONSTRUCTION EQUIPMENT  
TRUCKS AND TRAILERS



2019 CHALLENGER  
MT738

WEIGHT: 33,500 LBS  
DISTANCE HAULED: 994 MILES



KOMATSU  
D61EX-15E0

WEIGHT: 33,400 LBS  
DISTANCE HAULED: 1408 MILES

FAST AND EASY  
SHIPPING



JOHN DEERE  
DR24

WEIGHT: 18,947 LBS  
DISTANCE HAULED: 677 MILES



GRIAN  
BINS

WEIGHT: 10,000 LBS  
DISTANCE HAULED: 1163 MILES



2014 VOLVO  
L50G

WEIGHT: 20,745 LBS  
DISTANCE HAULED: 2455 MILES

GET FREE SHIPPING QUOTES TODAY

# Staff Notes

It is a few days after Memorial Day weekend as of this writing. We have had so much destructive weather in Texas this year. You may have seen the news reports of the seven people who lost their life over the holiday weekend in the Texas tornado. That neighborhood and the Shell station where many people took cover is about 20 minutes from my house. Watching the news reports and seeing so many lives lost and affected is a sobering reminder of how life is too short. The Shell station sits at Lone Oak Road and I-35 and that is the route that I take heading to and from the DFW area. In fact, Thursday evening I was returning from the airport and drove by that area not knowing 48 hours later it would be a site that would look much different. So be kind to one another and live life to the fullest. Every day is a precious gift given.



Kim Carroll

The week prior to Memorial Day weekend I was in New Orleans doing the site visit for our 40th Annual Conference and Trade Show to be held January 16 – 18. Harrah's has just been rebranded as Caesars and the hotel is in a prime location which sits between the French Quarter and the Garden District in New Orleans. For those who have attended the last two years, think of a combination experience of Nashville and San Diego. New Orleans offers Frenchmen Street for those who love music, the hotel is a short walk to Canal Street which offers many shops and restaurants, and the Riverwalk near the hotel is a really nice way to walk to the French Quarter. Now the work begins to put together a program that will pull together the elements of celebrating, educating, networking and an event you do not want to miss! Mark those dates on your calendar and plan now to join us in New Orleans. More to be shared soon.

Prior to that, we will be having the Summer Mixer, July 25-27 in the Des Moines area where the average high temperatures are in the mid-80s in July! This is a great central location to network in a relaxed setting and is open to all members. We will be staying at the AC Hotel Des Moines East Village & Republic on Grand. A few highlights this year will be touring the facilities of Colfax Tractor & Combine Parts, the World Food Prize Hall of Laureates which has a connection to agriculture, and the Iowa State Capital. We will also enjoy Friday night together taking in a minor league baseball game near to the hotel. We are thrilled that Colfax Tractor & Combine Parts is hosting the site visit this year. They have been a member of NTPDA

We're Excited!

Since we last gathered in California for our Annual Convention and Trade Show it's been busy here in the Des Moines Office as we work with Kim to make sure our July Summer Mixer is full of great things to see and do. You'll find a review of what to expect in this issue of The Bulletin and, yes, we're excited that you'll be coming to Des Moines next month.



Michael Libbie

In other news I took a trip to Washington, D.C. to, among other things, ask about the 2024 Farm Bill that is so very critical for our farmers and ranchers. Sen. Charles Grassley (R-IA) is the ranking member of the Agricultural Committee and he doubts that any farm bill will be authorized this session. That, of course, means that Congress will have to re-authorize the 2018 Farm Bill which, if you look at it sets pricing at 2018 levels...not 2024. Not good for agriculture.

Also inside this issue you'll find information on some of our new and current members. We've been fortunate to be able to retain and recruit both of which is vital to the health of any organization. One of the things that we're finding out is that many of our members may not be using all of the great benefits our Association offers. When you get a chance check the article on benefits in this issue and you may be surprised at what you get for an annual dues of just \$400!

Finally, thank you for the opportunity to serve the National Tractor Parts Dealer Association. We truly are...family.

Best wishes,

Michael

since 1990 and Michael recently visited their location. Check out his interview on page 11 to learn more about their story. You can see the full Summer Mixer itinerary on the NTPDA website. If you have not made plans to join us yet and would like to attend, complete the registration form on the NTPDA website. We look forward to seeing many of you there!

Until next time, have a safe summer!

Kim



## OUR ENGINE RANGE BY BRAND

Caterpillar<sup>®</sup>

C3.3B • 3013 • 3014 • 3024 • 3034 • 3044 • 3046 • 3054 • 3056 • 3064 • 3066 • C2.2 • C2.2 CRDI • C3.3  
C4.2 • C4.4 • C6.4 • C6.6

Cummins<sup>®</sup>

B & C Series 3.9 Liters • 4.5 Liters • 5.9 Liters • 6.7 Liters • 8.3 Liters

John Deere<sup>®</sup>

4024 • 5030 • 3.152 • 3.164 • 3.179 • 3029 • 4039 • 4045 • 4.202 • 4.219 • 4.239 • 4.270 • 4.276 • 6059 • 6068  
6076 • 6081 • 6090 • 6.101 • 6.303 • 6.329 • 6.359 • 6.404 • 6.414 • 6.466 • 6.531 • 6.619 • 4020 • 3016 • 4033

Perkins<sup>®</sup>

1204E • 1206E • 104-22 • 403C-15 • 403D-15 • 404C-22 • 404D-22 • 404F-22 • 704-30 • 804C-33 • 804D-33  
1004.40 • 1004.42 • 1006.60 • 1103 • 1104 • 1106 • 3.152 • 4.108 • 4.203 • 4.212 • 4.236 • 4.248 • 4.318 • 6.354

Yanmar<sup>®</sup>

3TNV70 • 3TNV76 • 3 & 4TNE84 • 3 & 4TNE84T • 3 & 4TNE88 • 4TNE94 • 4TNE98 • 4TNE106D & T  
3 & 4TNV84 • 4TNV84T • TK486 • TK486V • 4TNE86 • 4TNV86

Mitsubishi<sup>®</sup>

S4S • S4S DT • S4K • S6S • S6S D • S6S DT • S6K

Shibaura<sup>®</sup>

N4LDI • N843 • N843L • N844 • N844T • N844L • N844LT • N844L-D • N844LT-D • N844LTA-D • N844L-F  
N844LT-F

Komatsu<sup>®</sup>

3D70E • 3D76E • 3D84E • 3D88E • 4D106 • 4D84E • 4D88E • 4D94E • 4D94LE • 4D98E • S3D84E • S4D106

Kubota<sup>®</sup>

V2607 • V3307 • V1702 • V2003 • V2203 • V2403  
V3300 • V3800 • D1105 • V1505

IH/Navistar<sup>®</sup>

DT360 • DT414 • DT436 • DT437 • DT466

## OUR 3 DISTRIBUTION CENTERS

Covering 90% of the continental U.S. in 1-2 days ground shipments.

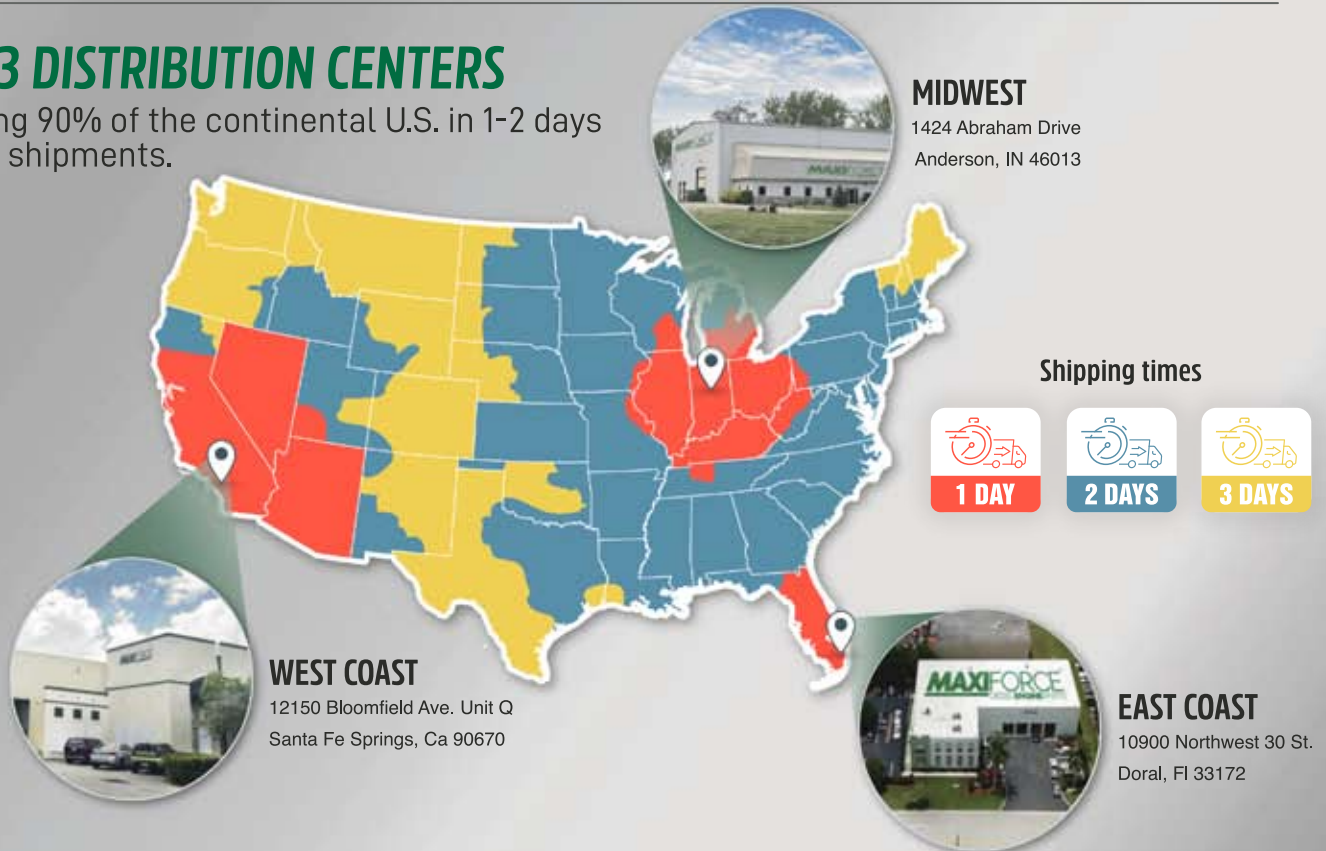

Warehouses located in Miami, FL - Anderson, IN - Los Angeles, CA

# HOW TO HAVE FAMILY MONEY CONVERSATIONS WITH ADULT PARENTS

*Provided by RBC Wealth Management and Craig Shaver*



Every year, we celebrate Mother's Day and Father's Day to honor the people we love and reflect back on the memories we've made with them. But as our loved ones age, adult children may want to also consider setting aside time to have a family money conversation.

Why? The simple fact is that at some point, mom or dad may need help organizing and/or managing their finances.

Sharing important information with one another today may help you and your family be prepared when the time comes that you or a sibling needs to step in to lend a hand. Important topics to consider in such a conversation include insurance, creating an inventory of your parents' assets and liabilities, ensuring your parents have enough money to provide for their retirement, establishing your parents' wishes regarding passing on their wealth in the event of their death, and more.

Talking about money, potential health considerations and other "private matters" may sometimes seem awkward and having these kinds of conversations as a family can be challenging.

But doing so today helps to ensure everyone is on the same page, making it easier for your family down the road.

To help navigate those potentially difficult areas, here are a few tips for meaningful family money conversations:

- Communicate your desire to help one another prepare to transition responsibilities.
- Discuss your feelings and needs regarding changing roles.
- Understand parental circumstances, needs and values regarding money.
- Consider parental health care, end of life and financial legacy wishes.
- Seek to align children's strengths with future duties.
- Identify professionals who may be able to provide assistance, as necessary.
- Commit to periodically revisiting the conversation to see if anything has changed.

For assistance or advice, contact a financial professional. They can help your family both before and after these important conversations.

*This article is provided by Craig Shaver, a Financial Advisor at RBC Wealth Management. The information included in this article is not intended to be used as the primary basis for making investment decisions. RBC Wealth Management does not endorse this organization or publication. Consult your investment professional for additional information and guidance.*

*RBC Wealth Management, a division of RBC Capital Markets, LLC, Member NYSE/FINRA/SIPC Investment and insurance products offered through RBC Wealth Management are not insured by the FDIC or any other federal government agency, are not deposits or other obligations of, or guaranteed by, a bank or any bank affiliate, and are subject to investment risks, including possible loss of the principal amount invested.*

*Leaders*

**Tractor & Combine  
Salvage**

*We play well with others!*

**1144 Toledo Avenue  
Dunlap, Iowa 51529**

**1-800-831-9290**

**Local (712) 643-2237**

e-mail: [leaders@iowatelecom.net](mailto:leaders@iowatelecom.net)





800.657.4343 | [aiproducts.com](http://aiproducts.com)

**QUALITY PARTS FOR ALL MAKES OF AG,  
TURF, & INDUSTRIAL EQUIPMENT**

- **SELECTION**  
OVER 160,000 PART NUMBERS, NEW ITEMS ADDED MONTHLY
- **QUALITY**  
EXCLUSIVE MULTI-STEP PRODUCT DEVELOPMENT PROCESS
- **WARRANTY**  
INDUSTRY LEADING 12-MONTH PARTS & LABOR
- **SERVICE**  
LOGIN AND ORDER ONLINE OR CALL OUR CUSTOMER SERVICE TEAM
- **DISTRIBUTION**  
STRATEGICALLY LOCATED WAREHOUSES OFFER QUICK DELIVERY  
THROUGHOUT THE US & CANADA

**MATCH THESE BENEFITS WITH OUR WHOLESALE FOCUSED PHILOSOPHY  
AND YOU KNOW THAT A&I PRODUCTS IS HERE TO SUPPORT YOU, YOUR  
BUSINESS, AND YOUR CUSTOMERS!**



# DID YOU KNOW... Benefits, We've got Benefits!

This information is on our NTPDA Website but figure you might want to take a look at the many benefits your membership receives for your annual dues of \$400. Let's go!

**Annual Conference and Trade Show** – Held in January each year, our annual conference and trade show allows you to see what's new, immerse yourself in industry intelligence and network with like-minded professionals. Mark your calendar for the 2025 Conference and Trade Show to be held at Harrah's New Orleans - January 16 - 18, 2025.

**Annual Summer Mixer** – Held in July each year, our annual summer mixer allows you to connect with members in a small setting to strengthen relationships. Plan now to join us July 25-27 in Des Moines, IA. Registration closes soon.

**NTPDA Ad Incentive** – NTPDA members can also receive up to \$300 credit annually if using member designated NTPDA logo in your ad copy. Each time you include the NTPDA logo in any of your ads



(excluding the NTPDA Bulletin) you will receive a \$25 credit with a limit of \$300 per year. All you need to do is send us a copy of the tear sheet showing publication and date. If those are not present on the tear sheet with the ad, then include a copy of the invoice. We will keep a tally sheet of each time you include the logo and at the end of the year we will send you a check.

*Continued on page 17*



## HARVESTING RELIABILITY, CULTIVATING PERFORMANCE

OE SEALING, FILTRATION AND VIBRATION CONTROL COMPONENTS FOR  
AGRICULTURAL AND CONSTRUCTION EQUIPMENT

FIND OUT MORE  
ABOUT OUR ENTIRE  
CORTECO OFFERING  
[Corteco.com/northamerica](https://Corteco.com/northamerica)



To learn more about Corteco Agriculture products contact [tom.eibel@fnst.com](mailto:tom.eibel@fnst.com)



# TISCO®

**With over 60,000 parts from TISCO, AgSmart, and many other top-quality brands, SMA has everything you need to repair or restore all major makes and models of tractors, combines, and other farm machinery.**

**With four distribution centers strategically located across the country, SMA is positioned to deliver exactly what you need, when you need it, directly to your parts counter the “SMA Way” - with service, responsiveness, professionalism, and fair dealing.**



HELPING FARMERS & FAMILIES GROW

[www.smalink.com](http://www.smalink.com)

800-643-0091

PO Box 2247 • Jonesboro, AR 72402

**AGsmart**



**TISCO**

**TRUPOWER**

**ICEBURN**

**STAR SMART**

**PICKSMART**

## LOADER PARTS SOURCE

Our long-time Member Loader Source is picking up the pace of their external marketing and offered us this information:

Things have been changing rapidly here at Loader Parts Source. The newly formed marketing department has been a whirlwind of activity as the dust settles on several new developments. Starting with the newest and most exciting development, we at LPS just welcomed in our new Integrator Dan Sheehan. He brings with him over twenty-two years of B2B and passion about improving customer experiences, developing team members, and winning.

Secondly our absolute rockstar Director of Supply Chain Operations, Chris, negotiated a new deal with our shipping partners. Previously, the oversized packages that our glass comes in would cost our customers an arm and a leg. That was before Chris negotiated with them to waive their \$40 demand fee and reduce costs by 35%. This all results in the better savings for our customers and a dedication to the fairest parts buying experience we can offer.

We welcomed in the new and improved Loader Parts Source website on May 9th.

Lastly we had a birthday very recently. On May sixteenth, our own Product Information Manager, Becky Brooks, celebrated her thirty-ninth birthday. Becky never fails to bring her positive attitude, uplifting sense of humor, and incredible references to the team. Thank you so much Becky for everything you do.

At Loader Parts Source we strive every day to make the customer's buying experience a fast, easy, and fair one. Our highly dedicated team fights every day to make sure that the savings are always passed on to the customer. We are still undergoing new and invigorating changes every day to create the fastest, easiest, and fairest experience for our customers we can!

## CALL NOTES WITH CY HILTY

One of our new Associate Members, Call Notes recently took part in an interview with Insight on Business which, from time to time, features an NTPDA Member.



If you click on the QR Code you'll be able to hear that conversation and what Call Notes can do for your business. Think customer service.



## CENTRAL AUCTION GROUP

A new member that joined us in February says they are the "Preferred Destination for Buyers and Sellers of Salvage Equipment Nationwide." Check them out and see what they have to offer. <https://www.centralauctiongroup.com/>

## KADDATZ

Another of our long-term Members, Kaddatz Auctioneering & Farm Equipment Sales, continue to do good in other parts of the world. Here is a brief article and a photo of their recent trip to Israel.

Travis Kaddatz led an Acts of Mercy humanitarian relief team to Israel. They left on 4-16-24 & returned safely on 4-27-24. Thank you to those who prayed and supported our mission.

Travis works with Kaddatz Auctioneering & Farm Equipment Sales in Hillsboro, TX.

*Go to the link below for more information or to support Acts of Mercy and their relief efforts.*



<https://actsofmercy.vomo.org/org/acts-of-mercy>

## COLFAX TRACTOR PARTS

It was great to be able to sit down with Jeff Bucklin from Colfax Tractor Parts and learn more about their business.



And, what's really cool is that Jeff and his father Bennie will be hosting a site visit and lunch during our Summer Mixer. To listen click that QR Code.



## ENVOY BUSINESS SYSTEMS

We understand how frustrating it is to accept credit card processing companies. But, what if a company comes along that will hold your hand and be there when you need them. We welcome a new Associate Member, Envoy Business Systems. Learn more about them here:

<https://envoybusinesssystems.com/>

## TRANSPORT DISTRIBUTION SERVICES

While the company has been in business since 2006 they recently joined our ranks to help in the area of freight. Our long-time friend Terry Maynard joined the firm and immediately encouraged their CEO to become an Associate Member of our group. Welcome and you can learn more about them here: <https://www.tdsd.com/>





# SCHOLARSHIP RECIPIENTS

Academic Year  
2024-25

The Scholarship Committee is proud to announce the 2024 scholarship recipients. This year there were 3 trade/technical scholarships and 22 collegiate scholarships awarded. The top two applicants were awarded \$5,000 each and the remaining scholarships were \$3,000 each with the sponsoring company contributing \$500 towards the scholarship award per recipient. A special thanks to our Scholarship Committee: Eric Shaul, Renae Jensen, Marian Levan, Erika Sudbrink, and Jake Walmer. The feedback we've gotten tells us that this member benefit is greatly appreciated and one that we hope continues for many years to come.

### CASSIDY RIDDLE

Purdue University  
Degree: Agronomy and Entomology  
Sponsoring Member: Bates Corporation  
Parents: Morris & Kimberlee Riddle



### LAUREN THRUSH

University of Delaware  
Degree: Physical Therapy  
Sponsoring Member: Hooper Inc.  
Parents: Kevin & DeAnne Thrush



### EMERY BLANKESPOOR

Iowa State University  
Degree: Animal Science/Pre-Vet  
Sponsoring Member: A&I Products  
Parents: Tim & Leah Blankespoor



### PIPER A COLLINS

Hays Academy of Hair Design  
Degree: Cosmetology  
Sponsoring Member: Abilene Machine, LLC  
Parents: Dr. Gene Collins and Misty Collins



### ALEXANDRIA CRAVEN

University of Michigan - Flint  
Degree: Nursing  
Sponsoring Member: Steiner Tractor Parts, Inc.  
Parents: Craig & Jaclyn Craven



### PRESLEIGH EICH

Northeast Iowa Community College  
Degree: Business  
Sponsoring Member: Parts ASAP – Fort Atkinson, IA  
Parents: Paul & Alycia Eich



### SAMANTHA EVERS

University of South Carolina Upstate  
Degree: Exercise and Sports Science  
Sponsoring Member: Rock Valley Tractor Parts  
Parents: Bryon & Jennifer Evers



### VICTORIA M FRASER

Century Community College  
Degree: Nursing  
Sponsoring Member: Parts ASAP – Hudson, WI  
Parents: John B. Fraser and Kay Fraser



**KAYLEE CORISTON**

Kent State University  
Degree: Speech Pathology & Audiology  
Sponsoring Member: Sparex Inc.  
Parents: Andrew & Candace Buonavolonta



**ALLIE GOUCHER**

University of Central Missouri  
Degree: Speech-Language Pathology  
Sponsoring Member: Cook Tractor Parts, Inc.  
Parents: Ralph & Crystal Goucher



**NATALIE KEMPEL**

University of Missouri – Columbia (Mizzou)  
Degree: Nursing  
Sponsoring Member: A&I Products  
Parents: Joshua & Mara Kempel



**KENDRIC LANGRECK**

Iowa State University  
Degree: Electrical Engineering  
Sponsoring Member: Parts ASAP – Fort Atkinson, IA  
Parents: Kenny & Jackie Langreck



**KRISTIE MOELLER**

University of South Dakota  
Degree: Occupational Therapy  
Sponsoring Member: Worthington Tractor Parts – Sioux Falls, SD  
Parents: Nicholas & Lisa Moeller



**NELSON T POLEN**

University of Wisconsin - River Falls  
Degree: Agricultural Engineering  
Sponsoring Member: Parts ASAP – Downing, WI  
Parents: Thomas & Dawn Polen



**KAYLEE GERDES**

Minnesota State University, Mankato  
Degree: Anthropology  
Sponsoring Member: Worthington Ag Parts – Worthington, MN  
Parents: Shawn & Bridget Gerdes



**FINLEY HOPE ROGSTAD**

University of Northern Iowa  
Degree: Biology  
Sponsoring Member: Parts ASAP – DeSoto, IA  
Parents: Chris & Shana Rogstad



**TREY SCHELLING**

South Dakota State University  
Degree: Mechanical Engineering  
Sponsoring Member: Rock Valley Tractor Parts  
Parents: Scott & Vicki Schelling



**BROOKE ANN SCHROEDER**

Marian University's Ancilla College  
Degree: Nursing  
Sponsoring Member: TTP – Diesel Power & Machine  
Parents: Travis & Wendy Schroeder



**ARDA ŞENOĞLU**

University of Illinois Chicago  
Degree: Architectural Studies  
Sponsoring Member: KEBA North America Corp.  
Parents: Umit & Seden Senoglu



**ASHLEY SHARKEY**

University of Michigan – Ann Arbor  
Degree: Secondary Education with German focus  
Sponsoring Member: Steiner Tractor Parts, Inc.  
Parents: Daniel & Lisa Warren





**TREYLIN THORSON**

University of Wisconsin - River Falls  
Degree: Computer Science & Information Systems  
Sponsoring Member: Parts ASAP – Downing, WI  
Parent: Amy Thorson



**ELLA VANDERVORT**

Penn State University  
Degree: Environmental Engineering  
Sponsoring Member: Hooper Inc.  
Parents: Kevin & Jennifer Vandervort



**RJ VOPAT**

University of Kansas  
Degree: Accounting  
Sponsoring Member: Abilene Machine, LLC  
Parents: Ray & Sara Vopat



**SHELBY WHITAKER**

Purdue University  
Degree: Agricultural Communication and Agricultural Sales & Marketing  
Sponsoring Member: Bates Corporation  
Parents: James & Destiny Whitaker



**PAIGE WHITE**

Northcentral Technical College  
Degree: Veterinary Technician  
Sponsoring Member: Parts ASAP – Black Creek, WI  
Parents: Werner & Dawn White



**Kaylee Coriston** - I am honored to be one of this year’s recipients of the NTPDA scholarship. I’d like to take this opportunity to thank you for helping fund my education at Kent State University! My educational pursuits would not have been possible without your generosity. Thank you for supporting me towards reaching my fullest personal and professional potential!

**Allie Goucher** – Thank you so much for the opportunity to receive your scholarship! I greatly appreciate the support and feel it is an honor to be chosen to represent this organization!

**Natalie Kempel** – I am honored to have received the 2024 National Tractor Parts Dealer Association Scholarship. This generous contribution will allow me to pursue by Bachelor of Science in Nursing degree at the University of Missouri – Columbia. After graduating and officially becoming a Registered Nurse, I look forward to helping improve and save the lives of others. Through your contribution and support, my goals are attainable, and I am excited to pursue my future career in Nursing.

**Kendric Langreck** – Thank you for selecting me to receive a \$3,000 scholarship. I will put this money to use when I go to Iowa State University for electrical engineering. I am honored to have been chosen for your scholarship. I greatly appreciate your support.

**Kristie Moeller** - Thank you so much for selecting me for the 2024 NTPDA Scholarship. The continued support of NTPDA means so much to me to be able to complete my education.

**Trey Schelling** – Thank you for selecting me as one of the recipients of this year’s scholarships. I am honored to be selected and truly humbled that you have chosen to invest in me and my academic future. I hope to honor your investment by continuing to pursue my mechanical engineering degree.

**Brooke Schroeder** – Thank you for your thoughtful consideration and contribution to my future. I will use your financial support towards my tuition to obtain my bachelor’s degree in the science of nursing. It is my intention to give back to my community by providing quality healthcare when I get my Nurse Practitioner license.

**Arda Şenoğlu** - I am sincerely grateful for you selecting me as the recipient of this scholarship. It is truly an honor, and I appreciate the opportunity it provides me to pursue my academic endeavors. Once again, thank you immensely for your support and belief in my potential.

**Ashley Sharkey** - I just wanted to say a huge thank you for awarding me with the NTPDA Scholarship! It will be an incredible help to me in regard to paying for my college career. Thank you all so much.

**Lauren Thrush** - I am incredibly grateful to be selected to receive the 2024 NTPDA Scholarship! I am thankful for this financial support and freedom that will allow me to pursue my academic and career goals.

**Ella Vandervort** – I am writing to express my deepest gratitude for the generous scholarship awarded to me. Your support means more to me than words can convey. Receiving this scholarship is not only a financial relief but also a tremendous encouragement for me to continue pursuing my passion for environmental sustainability. Your belief in my abilities motivates me to work harder and strive for excellence in my academic pursuit. Once again thank you from the bottom of my heart for your support.

**RJ Vopat** – I am writing to express my heartfelt gratitude for selecting me as a recipient for the NTPDA Scholarship. I am deeply honored and thrilled to have been chosen for this award. The eased financial burden will allow me to continue my success at KU.

# Let's Eat!

## Best Steak...Ever!

*We tried this at our place the other night and WOW! It takes a little prep but it is well worth the time and effort.*

### Ingredients:

8 oz Ribeye Steak  
Coarse Kosher Salt



### Steps:

Remove the steak from the refrigerator and let stand for 90 minutes;  
Place the steak on a cooking rack and cover each side with a generous amount of salt;  
Pre-heat your oven to 225 degrees;  
Place the cooking rack with the steak in the oven for 20 minutes or the inside temperature of the steak reaches 90 degrees;  
Finish in a HOT frying pan or on the grill making sure you get a good sear;  
Serve with sautéed asparagus and mushrooms.  
So, why the oven? It ages the steak and trust us...it is great! Enjoy!

<https://www.russelltractorparts.net/>

# PARTS

# NEW

# USED

# REBUILT

Let US  
Find That Part  
For YOU!



1-800-248-8883  
Scottsboro, AL



## GRATTON COULEE *Agri Parts LTD*

Phone: 780-754-2303

Tollfree: 888-327-6767

Proudly Serving

[www.gcparts.com](http://www.gcparts.com)

E-mail: [sales@gcparts.net](mailto:sales@gcparts.net)

Since 1988



**SALVAGING OVER 80 ACRES OF LATE MODEL TRACTORS & COMBINES  
USED, REBUILT AND NEW PART OPTIONS AVAILABLE. WE SHIP WORLDWIDE**



**WENGER'S**  
OF MYERSTOWN



# LARGE INVENTORY OF TRACTOR & SKID LOADER PARTS

- 50+ years in the tractor parts industry
- 10,000+ tractors dismantled for parts
- 180,000+ tractor part numbers
- 10,000+ skid loader part numbers

**IF WE DON'T HAVE IT, WE CAN FIND IT.**

**800-451-5240**  
**wengers.com**

# TECNOLOGIA PEREZ®



*For the past 60 years, Tecnologia Perez has been providing the best solutions for the agriculture industry by manufacturing high-quality and precision*

**KNIFE DRIVE BOX ASSEMBLY //**



**SPARE PARTS FOR COMBINE HARVESTERS //**



**WWW.TECNOLOGIAPEREZ.COM**

*60 YEARS OF RELIABILITY, QUALITY, AND SERVICE FOR ARGENTINA AND THE WORLD*



Did You Know, continued

**NTPDA Bulletin** – Members receive very favorable advertising rates in the Bulletin. Our quarterly publication is circulated to tractor parts dealers throughout the United States and Canada. It is also posted on our website to maximize your advertising exposure!

**NTPDA Job Board** – We know how tough it is to find and retain good help and we hope this free benefit will enable you to expand your search beyond your local area. All you have to do is send us a job posting (Position, Location, Hours, General Requirements, Contact and How to Apply) and we will create the post and place it in our Job Board section on our website. Visitors can then search by state to find available jobs. We will also link directly to your website so the prospective candidates can know more about your business.

**NTPDA Library** - Management tools for your business. Includes: The Social Media Bible, Embracing Change, Creating Customer Satisfaction, The Facebook Era, Measure What Matters, An Hour A Day Collection: Social Media Marketing, YouTube and Video Marketing, Facebook Marketing, Twitter Marketing, and LinkedIn Marketing, Financial Analysis, Understanding Financial Statements, Making Work Work, and Web Copy That Sells.

**NTPDA Member Referral Program** – This program could ultimately pay for your annual membership dues.

All you have to do is refer a new member to us and your membership dues for the following year are waived. It is that easy!

**NTPDA Parts Database** – Regular members can network together through the parts database. Individually no one dealer can carry every part for every customer, but as a group, NTPDA members are able to supply customers with an almost endless supply of new, used and rebuilt parts. Allied Information Networks has helped us in this endeavor by creating a database of the NTPDA members' inventories.

**NTPDA Scholarship Program** – The NTPDA Scholarship Program is offered each year to children of NTPDA members and their employees who will be full-time students at an accredited trade school, college, or university in the next academic year. This is open to all members and the value of the scholarship is \$3,000. Applications are available the first of February and are due the middle of March.

**NTPDA Website Listing** – We receive many unique visitors to the NTPDA site on a monthly basis. Members are arranged by State/Province and the company name, contact information, link to your website, and listing of your products/services is provided for visitors of our site to see. It is a form of year-round advertising for you and your company.

*Continued on page 21*



- ~ Specialize in Mahindra Tractor parts
- ~ Stock parts for Case IH
- ~ Excellent customer service



- ~ All parts are Brand New OEM & aftermarket
- ~ Quick shipping
- ~ Wide range of various tractor parts



[www.reubicontractorparts.com](http://www.reubicontractorparts.com)

Reubicon International, Inc.  
9701 Brown Lane, Unit 402 D  
Austin, TX 78754

**Call (512) 843-0130**

BBB ACCREDITED BUSINESS  
BBB Rating: A+

EST. 2005

# Plastics UNLIMITED, Inc.



JD SOUND GUARD CAB TOP

Providing all types of plastic materials:

- Thermoforming
- Castable Urethanes
- 5-Axis CNC Routing
- Design
- Fabrication
- Composite Molding
- Fiberglass

We also offer JD 4-POST CANOPY TOP, JD 4-POST HEADLINER,  
& JD 7000, 7200, 7400, 7600, 7800, 7210, 7410, 7610,  
7710, 7810 Series Cab Top

Visit us at: <https://www.plasticsunlimited.com/>

We also offer CASE IH 1896, 2096, 2294, 2394, 2594, 3294,  
3394, 3594, 4494, 4694, 4994 Series Cab Tops  
We also offer current Cat Cab Tops



New to our product line:  
CASE IH MAGNUM SERIES CAB TOP

Plastics Unlimited, Inc.

303 1st Street NW

Preston, IA 52069

[www.plasticsunlimited.com](http://www.plasticsunlimited.com)

(563) 689-4752

(563) 689-4757 fax

email: [sales@plasticsunlimited.com](mailto:sales@plasticsunlimited.com)

## COMING SOON!

# PARTS *ASAP*

AGRICULTURE • CONSTRUCTION

AN AMAZING NEW PARTS  
SHOPPING EXPERIENCE  
ONE PLACE TO BUY ALL  
OF YOUR AGRICULTURAL,  
CONSTRUCTION, AND  
INDUSTRIAL PARTS



**DOMINION**  
Equipment Parts



Yesterday's  
**TRACTOR CO.**  
Antique Tractor Headquarters



CONSTRUCTION EQUIPMENT  
**PARTS**



**TRACTORJOE**



**CONTRAX**

[PARTSASAP.COM](http://PARTSASAP.COM)

877-530-4430



# Quality Parts When YOU Need Them

Parts Express offers the highest quality of aftermarket tractor parts. We want to help keep your customers equipment running!

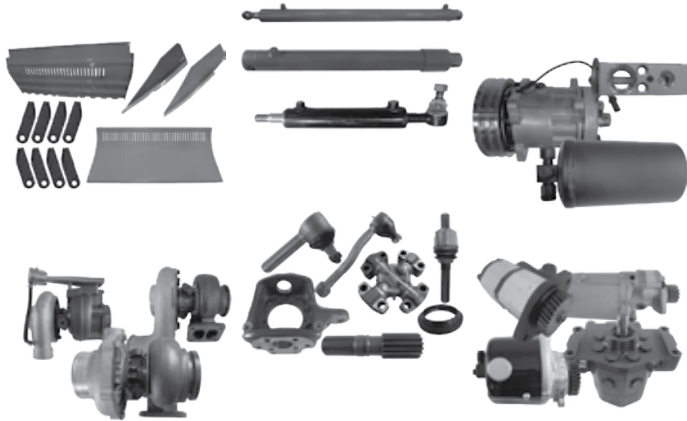

WAREHOUSE LOCATIONS: **SIoux FALLS · SIKESTON · LEESBURG · GOLDSBORO**  
Toll Free: 800-247-1237 [www.parts-exp.com](http://www.parts-exp.com)



Leading Aftermarket Seat Manufacturer and Distributor  
Nationwide in Agriculture, Construction & Turf Industries



**NEW! NorthStar,  
Ultra-Tow & Banjo**



**LED  
Work Lights**



**Mirrors/Monitor  
Brackets**



**Replacement  
Aftermarket Seats**



**Restoration Seats**



**Call for your FREE  
2024 Catalog!**

or Request a Copy Online at:  
<https://www.tractorseats.com/t-catalogrequest.aspx>

**TRACTORSEATS.com**

**(800) 328-1752**

[sales@tractorseats.com](mailto:sales@tractorseats.com)

K & M Manufacturing Co. | Renville, MN 56284





# AGRI PARTS

quality parts made in Italy

The best for your combine

**JOHN DEERE**  
GRAIN & FLEX HEADER:  
800 / 900F / 900R

AE41481  
Wobble  
box  
assy



**JOHN DEERE**  
WTS / CTS / ST550 / ST560 /  
ST570 / ST580 / W / T / C / S500 /  
S600 / 9500 / 9600

AH208345  
Top gearbox  
assy



**CNH**  
HEADERS DRAPER & FLEX  
DRAPER: MACDON / CASE

338670A1  
Wobble  
box  
assy



**JOHN DEERE**  
WTS / ST560 / ST580 / W / T /  
C / S500 / S600

DE20101  
Gearbox  
assy



**CNH**  
CASE GRAIN HEADER - N AM /  
CASE FLEX HEADER

87502685  
Wobble  
box assy



**CNH**  
CASE AF SERIES / NEW HOLLAND:  
CR / CX / CH SERIES

84320052  
Lower  
gearbox  
assy



**JOHN DEERE**  
900F & 900R SERIES

AH206402  
Gearbox  
assy



**JOHN DEERE**  
MACDON DRAPER 960  
BELT HEADER

AE34800  
Gearbox  
assy



**CNH**  
CASE AF SERIES / NEW HOLLAND:  
CR / CX / CH SERIES

87331084  
Top  
gearbox  
assy



AGRI PARTS REPRESENTATIVE FOR U.S.A.

John Danielson: 414 531 4944

email johndanielson@agriparts.it

website agripartsitaly.com



## Central Fuel Injection Service Co

712-362-4200 • 1-800-548-9464

### Your Classic Diesel Expert!

Service/Repair and exchanges for:



- Turbos
- Nozzles
- Injection Pumps

Home to:

Schroeter Diesel  
Technology Museum



[www.centralfuelinjectionservice.com](http://www.centralfuelinjectionservice.com)  
service@centralfuel.com

Central Fuel Injection Service Co.  
The Schroeter Diesel Technology Museum

Facebook:  
Central Fuel Injection Service Co.

# [www.SteinerTractor.com](http://www.SteinerTractor.com)

## Exclusive! IH side emblems

Built from aluminum; red background  
\$44.99 each



IHS712



IHS714



IHS716



IHS718

Built from aluminum; black background  
with creme numbers • \$44.99 each



IHS720



IHS722



IHS724



IHS726

Prices are for qualified dealers

Call Brandi at 1-833-787-7278 • 1-800-854-1373 fax • Prices do not include delivery and are subject to change without notice

**Bass Pro Shops/Cabela's Business Sales** - Our partnership with Bass Pro Shops/Cabela's Business Sales allows Corporate Discounts of 5-10% on general merchandise and 15-20% on Cabela's-branded merchandise. NTPDA Members can also leverage this benefit to order their own company-branded apparel with no set-up fee.

**Credit Card Processing** - If you use a credit card processing service, we offer special discounts through our two preferred members, Access Processing, based in Omaha and our newest member, Envoy Business Systems.

**ENET or TELEQUIP Discount** - Members receive a \$25.00 monthly discount on ENET or TELEQUIP level 1 or 2 service through Allied Information Networks. NOTE: The \$25.00 monthly discount equals a \$300.00 per year savings that comes very close to offsetting the \$400.00 per year membership dues.

**Estes Transportation** - No matter your freight transportation needs. As the largest, privately owned freight carrier in North America, Estes has the capacity, resources, footprint, and expertise to get your freight where it needs to go, when it needs to get there.

**Exclusive NTPDA Worldwide Travel Discount Program** - Members receive exclusive discounts as high as 50% and averaging 10-20% savings below market on all hotels and car rental suppliers around the world. We provide the best inventory, availability and rate-type options. Any hotel, any car, anytime, anywhere.

**Freight Partners Group** - Freight Partners Group would like to offer free set up on the FPG shipping platform which includes: LTL rates from over 100 qualified carriers, Domestic Small Parcel Rates from FedEx and UPS, International Small Parcel Rates from Deutsche Post (DHL), Last Mile Solutions which includes \$70 pallet rates within most major cities, On-board access to a full-coverage insurance option for coverage up to 10K in value. In addition to this, members have complimentary access to the Smart Shipping Advocacy Suite which includes Smart Shipper Alerts, Smart Shipper Updates, Smart Shipper Q&A Sessions, Smart Shipper Interviews, Seminars and Webinars. Annual membership is \$119 (less than \$10 per month) but all charges are waived for NTPDA members.

**ODP Business Solutions** - Office Depot® Member Benefits Program, previously Office Depot Business Solutions Division, has been rebranded to ODP Business Solutions™. Now a B2B-focused company serving small, medium and enterprise level companies like yours. NTPDA Members receive savings of up to 75% on the Best Value List of preferred products with free next-business-day delivery (minimum purchase required) or in-store and curbside pickup.

**Omaha Steaks** - Experience this Holiday or Grilling season. Savor an EXTRA 10% OFF SITEWIDE + FREE Shipping on select packages! Omaha Steaks are the perfect gift for friends, family or yourself for any occasion!

**TForce Worldwide Freight Program** - TForce Worldwide specializes in the expedited movement of new, used and remanufactured parts and equipment throughout the lower 48 and both to and from Canada. Their online logistics platform provides you instant access to the industries best rate from over 75 LTL (freight) carriers with nationwide range and reach.

**TForce Full Coverage Freight Insurance** - TForce has also arranged a full-coverage zero-deductible insurance option for new, used and remanufactured parts. NTPDA members who opt for this benefit will have their claims resolved within a matter of weeks at full replacement value.

**TForce Worldwide Small Parcel Program** - TForce Worldwide can also provide access to an online platform that provides special access to FedEx, UPS, DHL and Purolator small package for international and air freight shipments.

**Transport Distribution Services, Inc. (TDS)** is your agile partner, capable of tailoring diverse strategies to meet your unique needs. We integrate state-of-the-art technology, advanced logistics solutions, and unwavering customer service to deliver cost-saving efficiencies that propel your success.

**UPS® Savings Program** - NTPDA and UPS® took the guesswork out, and put the easy in. Members now have access to new flat discounts that include savings of 50% on Domestic Next Day/Deferred, 30% on Ground Commercial / Residential, up to 50% on additional services and the UPS Smart Pickup® service for free.

**Receive enhanced protection.** Let UPS help you discover the brighter side of your supply chain by protecting your shipments and your bottom line. Choose when you want to protect your shipments and for how much by simply entering the value of your shipment in the declared value of your UPS® approved shipping system and you are on your way to the brighter side.

**Print and produce a wide variety of marketing materials online.** The UPS Store® provides members with quick, affordable and effortless digital printing solutions with easy online ordering and expert customer service.





# KADDATZ

AUCTIONEERING & FARM EQUIPMENT SALES

[www.kaddatzequipment.com](http://www.kaddatzequipment.com)

**Pray For Israel  
& For Ukraine**



Alvin Kaddatz  
Lic. TXS6676 (TX)  
Lic. AR2283 (AR)



Travis Kaddatz  
Lic. TXS16308



Carson Kaddatz  
Associate Auctioneer

## ★ REAL ESTATE ★ FARM/RANCH ★ TERP EQUIPMENT ★ HEAVY EQUIPMENT ★ VEHICLES/TRAILERS

- Analyze your situation and develop a plan for your needs
- Advertise in the best media for your location
- Site and Asset preparation, inspection, supervision, registration
- Professional team of auctioneers, clerks, ringmen, and office and security personnel

**We have a 15% rebate on new parts ordered at Farmstore.online.  
We can sell your surplus vehicles and equipment anywhere in the US.**

## ★ APPRAISAL SERVICES ★

- Estate Administration/Probate
- Loan Collateral
- Livestock
- Guardianships
- Insurance Replacement Value
- Construction
- Bankruptcy/Liquidation
- Equipment
- Motor Vehicles



535 HCR 4223, Hillsboro, TX • (254) 582-3000 • [akaddatz@yahoo.com](mailto:akaddatz@yahoo.com)

*"Let us not become weary in doing good, for at the proper time we will reap a harvest if we do not give up." Galatians 6:9*



### YOUR #1 SOURCE FOR AGRICULTURAL & INDUSTRIAL

#### REPLACEMENT PARTS FOR THOUSANDS OF APPLICATIONS



INJECTORS



PUMPS



PERFORMANCE MODULES



TURBOCHARGERS



REPLACEMENT KITS



AIR INTAKE PRECLEANERS



Area Diesel Service, Inc.

1-800-637-2658

[f](#) [X](#) [@](#) [in](#) [v](#) [d](#)



## USED REPAIR PARTS

- Wheel Loaders, Crawlers,
- Track Excavators,
- Loader Backhoes, Skidders,
- Skid-Steer Loaders,
- Engines and Transmissions

*"Rely on our Experience - Est. 1967"*



# Schaefer Enterprises

800-626-6046 ~ 618-833-5498

[www.sew|parts.com](http://www.sew|parts.com) - [parts@sew|parts.com](mailto:parts@sew|parts.com)



Hwy 3, PO Box 136  
Wolf Lake, IL 62998





# BE...NICE.

*by Michael Libbie*

They say there is a saying around here that we're "Iowa Nice" and for the most part that's true. However, every so often we scratch our collective heads at emails or letters that get sent out by big companies that are anything but "Iowa Nice". Here are two examples:

We received a letter from Mid-American Energy letting us know they needed to do an "inspection of your gas meter." But it was the next paragraph in bright red that got us: "Unless you comply with this demand we will be forced to turn off your utilities and it will cost you \$700 to have them turned back on!" Uhm...really? So we called the phone number and were directed to an automated service

that had us punching an endless series of numbers only to be disconnected. We turned to social media to air the issue and the company responded right away. Fixed.

The second was from our bank, Wells Fargo. They wanted a physical address and not our post office box and if we didn't comply with their demand they would, "...cancel all of your accounts by July 13!" And, yes, that was in all bold copy as well. It was an easy online fix but...really?

The point of this is how a company can damage their brand by faulty communication. Word up...be nice.



### **DREAMING OF THE PERFECT SOFTWARE THAT WILL GIVE YOU A COMPETITIVE EDGE?**

Allied Software is designed to help you manage your parts business more efficiently, so you can focus on what you do best - **SELLING PARTS**

- \* **Business & Inventory Management Software**
- \* **Parts Locating & Selling**
- \* **ECommerce**
- \* **Ebay Listing & Management Tool**

Our software is easy to use and affordable, so you can start using it today to improve your Parts Business

Contact us today to learn more about our software and how it can help you sell more parts.

**800-866-0466**



# SUMMER MIXER IN DES MOINES

We're really excited to host our Summer Mixer in Des Moines, Iowa one of the cities that gave birth to the National Tractor Parts Dealer Association nearly forty years ago! We've got so many fun things to share with you from a fantastic host hotel, The AC in the East Village, a site visit

and lunch at Colfax Tractor Parts, and a baseball game with the Iowa Cubs.

The Dates are July 25 – 27 and our hotel is just 15 minutes from the Des Moines International Airport. See you in Des Moines and remember...the S's are silent!





# Greetings from Greasy Girl



By Terri Stevens

Dear Friends,

Happy Summertime!

Hope you all have had a tall glass of lemonade or a piece of watermelon. Those are all signs to me that it is summer. It is crazy how fast the months and the years go. It seems, for all of us, it is like we are in a fast car and the weeks seem like days and the months seem like weeks.



So that brings me to my current situation. My parents are aging, they are 90 and 88! I must have good genes. LOL. Their life is changing too fast for them, and it is hard for them to accept the changes that are happening. It makes me realize how truly fast a lifetime goes. So have you thought about getting old and how it will look? It is a hard thing to think about but, last time I checked, none of us are getting out of here alive. My Grandma lived to be 97 and I asked her one time what was her favorite age and she said, "Where I am at."

I have thought so much about that comment. Every age brings blessings and hardships. Remember being a teenager and having the world before you and you felt like you were indispensable. Then you get married and then you have kids! You work and work and work!

Life is truly an adventure no matter what. A lot of it is how you look at it. Enjoy the place you are at!

The Bible says life is a vapor and the older I get the more I realize that. Be proactive and think about your future. My parents are living in a 4-story house with 5 acres and the laundry is in the basement. They didn't think ahead and now they aren't willing to move.

Yike's! We have seen a lot of our charter members pass this year — the Schaffer's and Eric's Dad. It is so important that we live our lives intentionally and that we put God first and others second and ourselves last. We need to love like no other and realize that Love Never Fails.

So, wherever you are in life — young or old — make the most out of it. Be proactive, stay active and stay positive. Life is good! We are all very blessed! Share a smile or a glass of lemonade, or a slice of watermelon and enjoy the summer.

*Ecclesiastes 3:1: There is a time for everything, and a season for every activity under heaven.*

Blessings,  
Greasy



**diesel specialties inc.**  
*Serving you from Sioux City, IA since 1964*

Extensive parts inventory and diesel repair specialists to help you. **Contact us today.**

dieselspecialties.com • service@dieselspecialties.com • 800.475.4827

# RELIANCE™

The Right Parts to Transform Your Engine.

ReliancePowerParts.com

800-342-2545



# RELIANCE PREMIUM REPAIR PARTS



ALLIS CHALMERS | CASE IH | CATERPILLAR | CUMMINS | FORD | IVECO | JOHN DEERE | KUBOTA | NEW HOLLAND | OLIVER | PERKINS | WHITE AND MORE!

## EVERYTHING YOU NEED FOR YOUR NEXT ENGINE REBUILD



ENGINE CYLINDER COMPONENTS

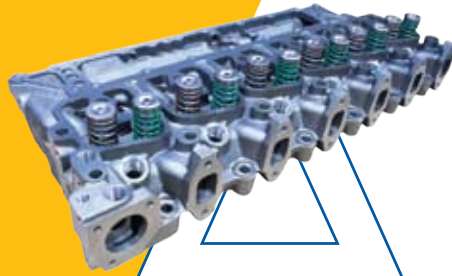

ENGINE CYLINDER HEADS & PARTS

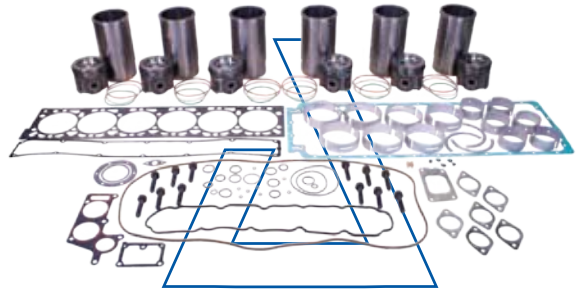

ENGINE KITS



LONG BLOCKS

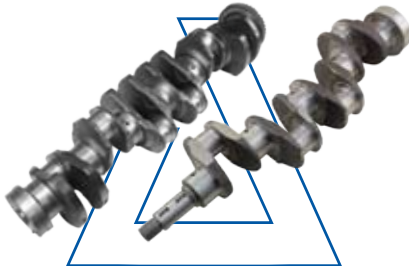

CRANKSHAFTS & PARTS

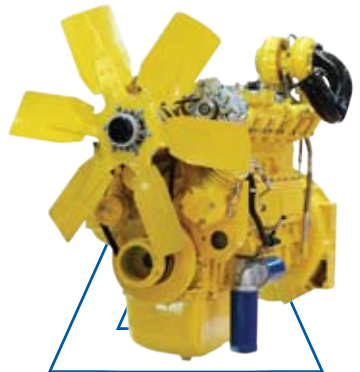

COMPLETE ENGINES

*\*All parts are sold separately.*

© Reliance a Nivel HD brand 2023. All manufacturer names, numbers, symbols & descriptions are for reference purposes only. It is not implied in any way that the items are a product of the manufacturer referenced. OEM makes are registered trademarks of their respective owners.

# Days Gone By





**NTPDA**  
P.O. Box 1181  
Gainesville, TX 76241

PRESRT. STD.  
U.S. POSTAGE  
**PAID**  
Sherman, TX  
75090  
Permit No. 125

RETURN SERVICE REQUESTED

## **THANK YOU ADVERTISERS!**

	PAGE		PAGE
A&I Products .....	8	Maxiforce.....	6
AgriParts .....	20	Parts Express.....	19
All States .....	18	Plastics Unlimited .....	18
Allied Information Networks.....	23	Reliance.....	26
Area Diesel .....	22	Reubicon .....	17
Call Note .....	4	Russells.....	15
Central Fuel.....	20	Schaefer .....	22
Corteco .....	9	SMA TISCO.....	10
Diesel Specialties .....	25	Steiner .....	20
Gratton Coulee .....	15	Tecnologia Perez .....	16
K&M .....	19	Tractor House .....	4
Kaddatz .....	22	TVH .....	3
Leaders .....	7	Wengers .....	16